

Fully assembled flush mount security transaction window system. Includes fixed pane to protect staff, along with a speaker and option of two drawer sizes.

Ideal for pharmacies, banks, convenience stores, dispensaries, stadiums, and municipal or corrections projects.

Choose the appropriate glazing for your site:

- ◇ **INSULATED** 3/4" insulated tempered glass.
- ◇ **ENERGY SAVER** Choose 3/4" Solarban 70XL Insulated Low-E glass to maximize energy-efficiency and staff comfort. Estimated to save 33% on energy costs associated with the window. NFRC Rated.
- ◇ **HURRICANE** Choose Smash & Grab Impact Rated Glazing (Miami Dade NOA 16-0307.06 – Impact Zones)
- ◇ **SECURITY** Choose Level 1 or Level 3 Bullet Resistant Lexan or Smash & Grab glazing for protection from forced entry. When Bullet Resistant Lexan is selected, extrusions are lined with Lumiguard.



603 pictured: Dark Bronze anodized finish.

Choose the appropriate drawer height for your transactions (transfer area dimensions)

- ◇ Product Drawer: 18-1/4"W x 14-1/4"D x 9-1/2"H
- ◇ Cash Drawer: 9-1/2"W x 14-1/4"D x 2-1/4"H without deal tray

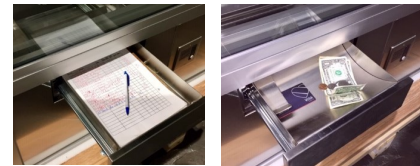

Cash drawer with removable deal tray 2 1/4" high

OVERALL FRAME SIZE INCLUDING DRAWER/SPEAKER HOUSING

- ◇ 47-1/2" W x 58-1/2"H (43-1/2"H Fixed Window)
- ◇ 47-1/2"W x 50-3/4"H (35-3/4"H Fixed Window)



Product Drawer interior and exterior view. 9 1/2" high

STANDARD FEATURES:

- ◇ Anodized aluminum extrusions and stainless steel combine to give you an attractive window that will not rust, pit or weather
- ◇ Fully assembled, pre-glazed and ready to install
- ◇ Two Drawer Options—transfer area dimensions:
 - Product Drawer: 18-1/4"W x 14-1/4"D x 9-1/2"H
 - Cash Drawer: 9-1/2"W x 14-1/4"D x 2-1/4"H without deal tray
- ◇ Dark Bronze or Clear Anodized Aluminum window frame
- ◇ One year parts & labor limited warranty
- ◇ On-staff tech support / stocked parts / nationwide network of service providers

OPTIONAL FEATURES

- ◇ Glazing:
 - 3/4" Clear insulated
 - 3/4" Solarban 70 XL Insulated Low E
 - 3/4" Smash & Grab
 - 3/4" Lexan Level 1
 - 1 1/4" Lexan Level 3
- ◇ Powder Coat Paint—Tiger Drylac

ALL WINDOWS ARE SHIPPED COMPLETELY PRE-ASSEMBLED, FULLY GLAZED AND READY TO INSTALL.

Installation / Owners manual can be retrieved online: www.ready-access.com

Must be installed level, square and plumb.

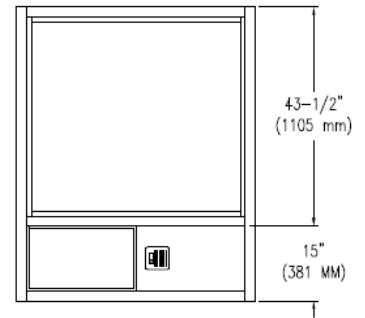
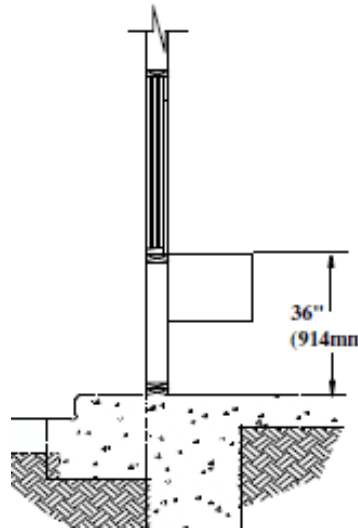
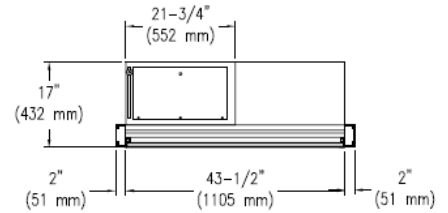
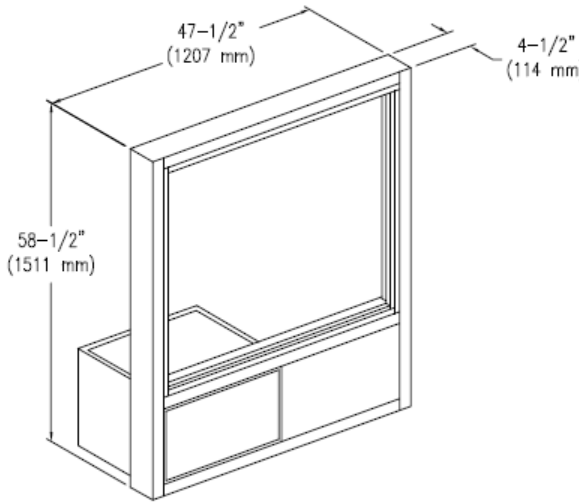

Specify Drawer Position - L or R from outside view

Specify Drawer Type

- ◇ Product Drawer: 18-1/4"W x 14-1/4"D x 9-1/2"H
- ◇ Cash Drawer: 9-1/2"W x 14-1/4"D x 2-1/4"H without deal tray

ROUGH OPENING

Rough opening should be 1/2" larger than frame size to allow for shimming. (defer to preference of glazer if mounting in storefront)

For interior counter sill height of 36", rough opening should be set 18 3/4" H from interior finished floor.

- ◇ 47 1/2" W x 58 1/2"H (RO 48"W x 59"H)
- ◇ 47 1/2"W x 50 3/4"H (RO 48" x 51-1/4")

ELECTRIC REQUIREMENTS—SPEAKER

Speaker supplied with 115v cord & plug.

Positioned opposite drawer.